



MAGNESIO



MAGNESIO 1



MAGNESIO reflectasol

- ALUMINIO
- PVC
- MIXTO ALU-MADERA
- LACADO COLOR
- IMITACIÓN MADERA
- ANODIZADO
- FOLIADO

# ALUPORTA

Serie: RANURADOS

RANURADOS



NIQUEL 3



NIQUEL 1



NIQUEL



NIQUEL 2

- ALUMINIO
- PVC
- MIXTO ALU-MADERA
- LACADO COLOR
- IMITACIÓN MADERA
- ANODIZADO
- FOLIADO

# ALUPORTA

Serie: ELEMENTS

ELE  
MEN  
TS



MERCURIO



MERCURIO 1



MERCURIO 3



MERCURIO 2

- ALUMINIO
- PVC
- MIXTO ALU-MADERA
- LACADO COLOR
- IMITACIÓN MADERA
- ANODIZADO
- FOLIADO





# ALUPORTA

Serie: EVOLUCION

EVO  
LUCI  
ON

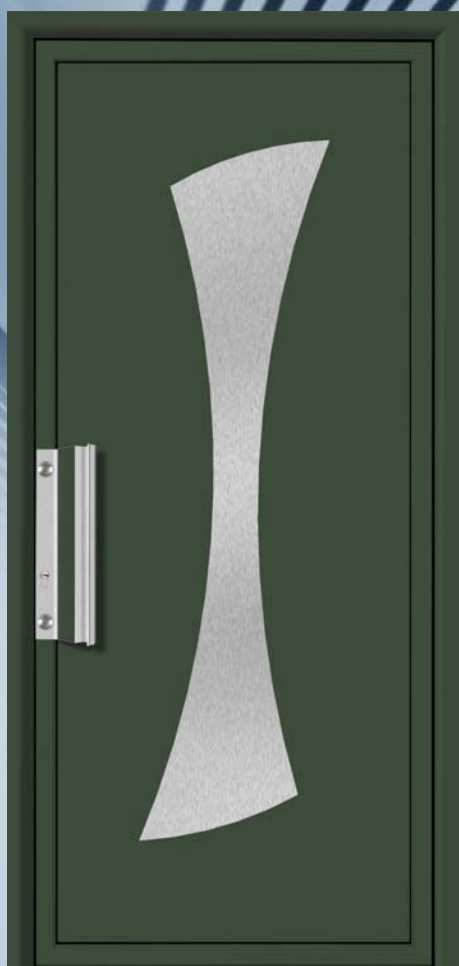

PLATINO A



PLATINO A1

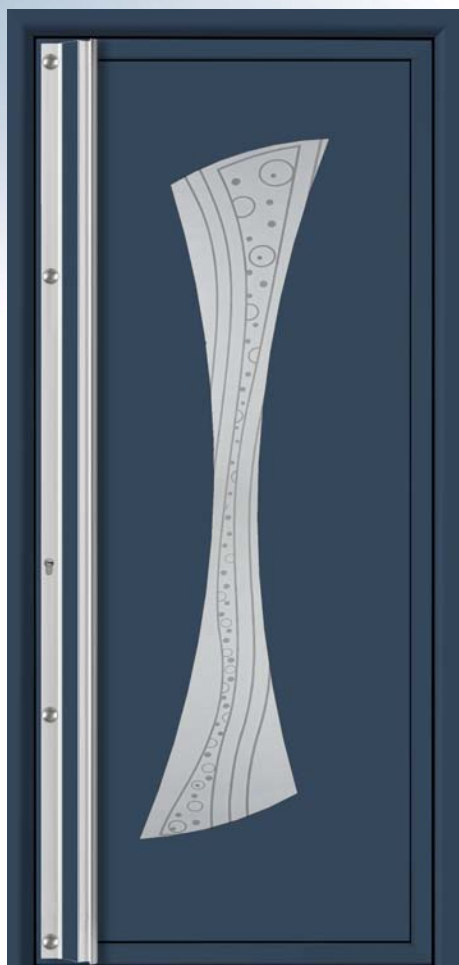

PLATINO A2



PLATINO A3

- ALUMINIO
- PVC
- MIXTO ALU-MADERA
- LACADO COLOR
- IMITACIÓN MADERA
- ANODIZADO
- FOLIADO



# ALUPORTA

Serie: EVOLUCION

EVO  
LUCI  
ON



PLATINO B



PLATINO B1



PLATINO B2



PLATINO B3

- ALUMINIO
- PVC
- MIXTO ALU-MADERA
- LACADO COLOR
- IMITACIÓN MADERA
- ANODIZADO
- FOLIADO



# ALUPORTA

Serie: ELEMENTS

ELEMENTS



OSMIO 2



OSMIO 3



OSMIO



OSMIO 1

- ALUMINIO
- PVC
- MIXTO ALU-MADERA
- LACADO COLOR
- IMITACIÓN MADERA
- ANODIZADO
- FOLIADO

# ALUPORTA

Serie: EVOLUCION

**EVO  
LUCI  
ON**



**PLOMO 1**



**PLOMO 2**



**PLOMO 3**



- ALUMINIO
- PVC
- MIXTO ALU-MADERA
- LACADO COLOR
- IMITACIÓN MADERA
- ANODIZADO
- FOLIADO



# ALUPORTA

Serie: EVOLUCION

**EVO  
LUCI  
ON**



POLONIO A



POLONIO B



POLONIO C



POLONIO A1



POLONIO B1



POLONIO C1

- ALUMINIO
- PVC
- MIXTO ALU-MADERA
- LACADO COLOR
- IMITACIÓN MADERA
- ANODIZADO
- FOLIADO

# ALUPORTA

Serie: EVOLUCION

**EVO  
LUCI  
ON**



POLONIO A2



POLONIO B2



POLONIO C2



POLONIO A3



POLONIO B3



POLONIO C3



- ALUMINIO
- PVC
- MIXTO ALU-MADERA
- LACADO COLOR
- IMITACIÓN MADERA
- ANODIZADO
- FOLIADO

# ALUPORTA

Serie: EVOLUCION

EVOLUCION

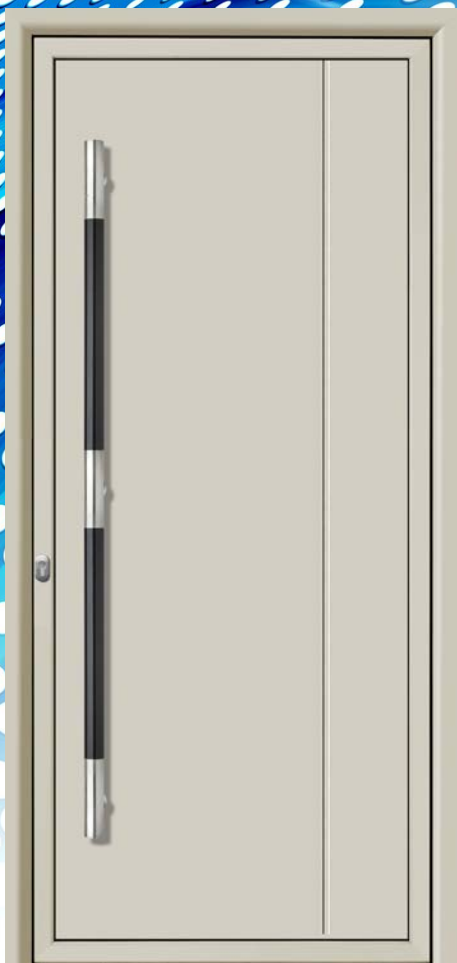

NEON



NEON A



NEON A nogal

- ALUMINIO
- PVC
- MIXTO ALU-MADERA
- LACADO COLOR
- IMITACIÓN MADERA
- ANODIZADO
- FOLIADO



# ALUPORTA

Serie: ELEMENTS

ELE  
MEN  
TS



PALADIO



PALADIO 1



PALADIO 3



PALADIO 2

- ALUMINIO
- PVC
- MIXTO ALU-MADERA
- LACADO COLOR
- IMITACIÓN MADERA
- ANODIZADO
- FOLIADO



# ALUPORTA

Serie: ELEMENTS

ELEMENTS



POTASIO 2



POTASIO 3



POTASIO



POTASIO 1

- ALUMINIO
- PVC
- MIXTO ALU-MADERA
- LACADO COLOR
- IMITACIÓN MADERA
- ANODIZADO
- FOLIADO



# ALUPORTA

Serie: RANURADOS

RANURADOS



SILICIO A



SILICIO



SILICIO A embero

- ALUMINIO
- PVC
- MIXTO ALU-MADERA
- LACADO COLOR
- IMITACIÓN MADERA
- ANODIZADO
- FOLIADO





**RADON A**



**RADON B**



**RADON C**



**RADON A1**

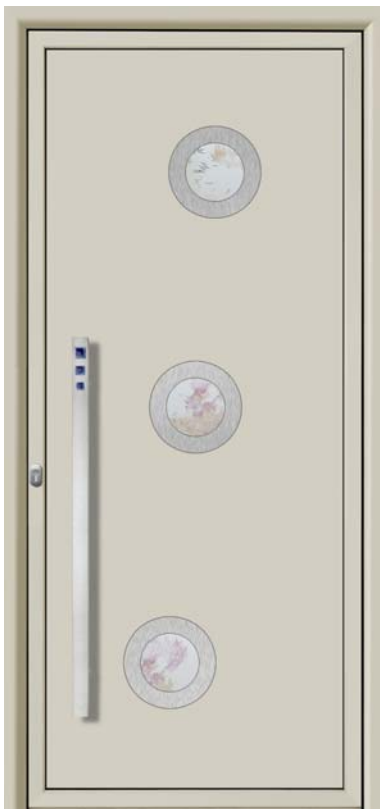

**RADON B1**



**RADON C1**

- ALUMINIO
- PVC
- MIXTO ALU-MADERA
- LACADO COLOR
- IMITACIÓN MADERA
- ANODIZADO
- FOLIADO

# ALUPORTA

Serie: EVOLUCION

# EVO LUCI ON



RADON A2



RADON B2



RADON C2



RADON A3



RADON B3



RADON C3



Vista interior  
vue intérieure  
inside view

- ALUMINIO
- PVC
- MIXTO ALU-MADERA
- LACADO COLOR
- IMITACIÓN MADERA
- ANODIZADO
- FOLIADO

# ALUPORTA

Serie: EVOLUCION

EVOLUCION



XENÓN A



XENÓN A1



XENÓN A2



XENÓN A3

- ALUMINIO
- PVC
- MIXTO ALU-MADERA
- LACADO COLOR
- IMITACIÓN MADERA
- ANODIZADO
- FOLIADO



# ALUPORTA

Serie: EVOLUCION

EVOLUCION



XENÓN B



XENÓN B1



XENÓN B2



XENÓN B3

- ALUMINIO
- PVC
- MIXTO ALU-MADERA
- LACADO COLOR
- IMITACIÓN MADERA
- ANODIZADO
- FOLIADO

# ALUPORTA

Serie: EVOLUCION

**EVO  
LUCI  
ON**



TELURO



TELURO 1



TELURO 2



TELURO 3

- ALUMINIO
- PVC
- MIXTO ALU-MADERA
- LACADO COLOR
- IMITACIÓN MADERA
- ANODIZADO
- FOLIADO

# ALUPORTA

Serie: ELEMENTS

ELE  
MEN  
TS



SODIO



SODIO 1



SODIO 3



SODIO 2

- ALUMINIO
- PVC
- MIXTO ALU-MADERA
- LACADO COLOR
- IMITACIÓN MADERA
- ANODIZADO
- FOLIADO





# ALUPORTA

Serie: EVOLUCION

EVO  
LUCI  
ON



SELENIO



SELENIO 1



SELENIO 2



SELENIO 3

- ALUMINIO
- PVC
- MIXTO ALU-MADERA
- LACADO COLOR
- IMITACIÓN MADERA
- ANODIZADO
- FOLIADO

# ALUPORTA

Serie: RANURADOS

RANURADOS



VANADIO 2



VANADIO 1



VANADIO 3



VANADIO

- ALUMINIO
- PVC
- MIXTO ALU-MADERA
- LACADO COLOR
- IMITACIÓN MADERA
- ANODIZADO
- FOLIADO

# ALUPORTA

Serie: ELEMENTS

ELEMENTS



TITANIO 2



TITANIO 3



TITANIO



TITANIO 1

- ALUMINIO
- PVC
- MIXTO ALU-MADERA
- LACADO COLOR
- IMITACIÓN MADERA
- ANODIZADO
- FOLIADO



# ALUPORTA

Serie: ELEMENTS

ALU  
MIXTO  
TSUN



RUBIDIO



RUBIDIO 1



RUBIDIO 3



RUBIDIO 2

- ALUMINIO
- PVC
- MIXTO ALU-MADERA
- LACADO COLOR
- IMITACIÓN MADERA
- ANODIZADO
- FOLIADO



**EVO  
LUCI  
ON**



**YODO A**



**YODO A1**



**YODO A2**



**YODO A3**

- ALUMINIO
- PVC
- MIXTO ALU-MADERA
- LACADO COLOR
- IMITACIÓN MADERA
- ANODIZADO
- FOLIADO

# ALUPORTA

Serie: EVOLUCION

# EVO LUCI ON

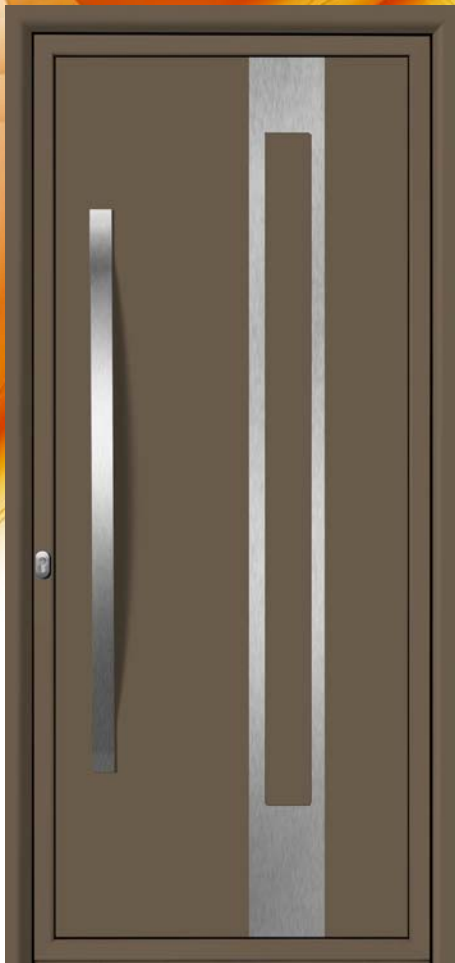

YODO B



YODO B1



YODO B2



YODO B3



- ALUMINIO
- PVC
- MIXTO ALU-MADERA
- LACADO COLOR
- IMITACIÓN MADERA
- ANODIZADO
- FOLIADO





# ALUPORTA

Serie: RANURADOS

RANURADOS



RODIO



RODIO 3



RODIO 1



RODIO 2

- ALUMINIO
- PVC
- MIXTO ALU-MADERA
- LACADO COLOR
- IMITACIÓN MADERA
- ANODIZADO
- FOLIADO

# ALUPORTA

Serie: CRISTAL



GIGA



MEGA



PETA



TERA

## PUERTA COMPLETA

ALUMINIO - ALUMINIUM - ALUMINIUM

### SERIE ALUMINIO: LA MÁS ECONÓMICA

Aluporta tiene en todos sus diseños la innovación la alta calidad y las soluciones. En la serie aluminio económica hemos optado por evitar el junquillo del panel, la colocación de doble sistema de cortavientos inferiores, dos juntas de epdm batientes y una tercera junta central EPDM, que hacen una puerta estanca a las inclemencias del tiempo, aire, polvo, lluvia, etc. También en lo concerniente a la seguridad, diseñamos una cerradura especial de 3 puntos en forma de gancho y un cono antipalanca.

LACADOS  
IMITACIÓN  
MADERA



LACADOS  
GAMA RAL



Disponible en cualquier color de la gama RAL y en lacado imitación madera.  
Disponible en toutes couleurs de la gamme RAL autant pour des lacques de l'imitation bois.  
Disposal in all the colours of the range RAL and also for the lacquer of wood-imitation.

**SÉRIE ALUMINIUM: LA PLUS ÉCONOMIQUE**  
Aluporta étend sur tout ses dessins à l'innovation la grand qualité et les solutions. Dans la série économique d'aluminium nous avons opter le montage du panneau sans joint, la colocation de deux systèmes coupe-vent inférieurs, deux jointures de Epdm battants et un troisième joint central Epdm, que fond un arrête aux intempéries, air, poussière, pluie, etc. De même concernant la sécurité-nous dessinons une serrure spéciale trois points en forme de crochet et un cône antidegoudage.

**SERIE ALUMINIUM: THE MOST ECONOMICAL**  
Aluporta tend to all his designs to the innovation the high quality and the solutions. In the economical serie of aluminium we choose to prevent the jonquil of the panel door, the collocation of double system of inside wind breaker, two joints of EPDM leaf and a third central joint epdm, which make a door stablish to the harshness of the weather, air, dust, rain, etc. Also concerning the security - we have designed a special locking with three points in form of a hook and a cone anti-lever.

Poliuretano inyectado de alta densidad de 16 mm 150 kgs/m<sup>3</sup>  
Mousse de Polyuréthane d'une haute densité: 16 mm.1150 Kgs/m<sup>3</sup>.  
Injected Polyurethane foam with a high density of 16 mm.1150 Kgs/m<sup>3</sup>.

2 Chapas de aluminio de 2 mm. de espesor.  
2 Tôles d'aluminium de 2 mm. d'épaisseur.  
2 Aluminium sheets with 2 mm. of thickness.

Detalle de sección de perfil.  
Détail de la section du profil.  
Detail of the profil section.



### SECCIÓN HORIZONTAL

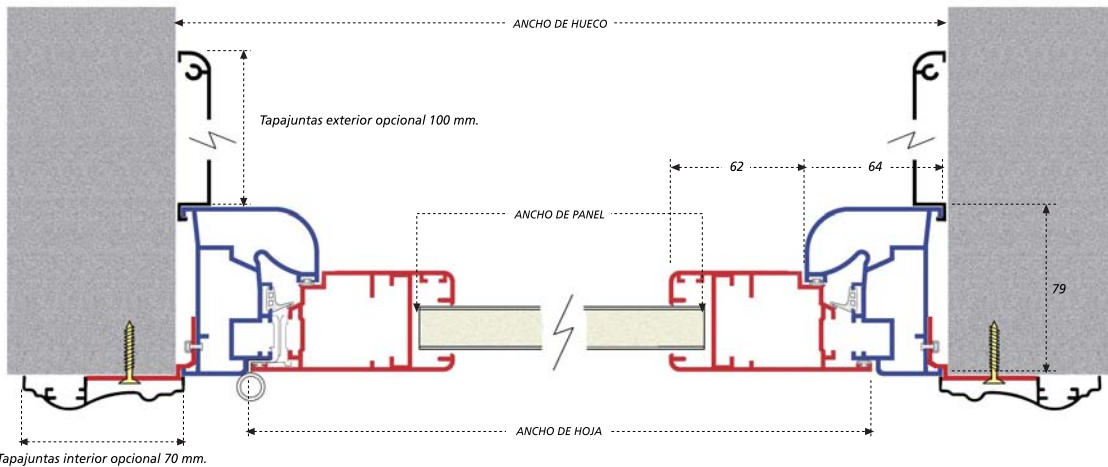

### SECCIÓN VERTICAL

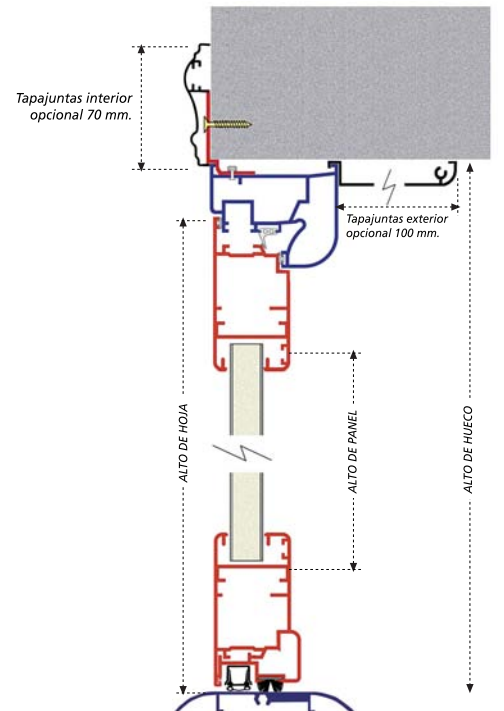

66



Conos antipalanca  
Cônes anti-degoudage  
Cones antilever

3 bisagras regulables  
3 charnières regulable  
3 regulable hinge

Detalles de bisagra.  
Détails de charnière.  
Details of hinge.

Cerradura de seguridad especial de gancho, 3 puntos.  
Serrure de sûreté spéciale de crochet, 3 points.  
Safety locking special with hook, 3 points.

Doble sistema cortavientos estanco.  
Double system coupe vent d'étanchéité.  
Double system and waterproof wind breacer.



#### SERIE ALUMINIO ROTURA TÉRMICA: LA MÁS RESISTENTE

Este tipo de puerta ha sido pensada para dar la mayor seguridad a la entrada de la vivienda, con sus tres juntas de EPDM y doble cortavientos inferior, la convertimos en una puerta estanca. La rotura térmica evita las condensaciones propias del aluminio y permiten la doble terminación interior – exterior (bicolores). También en seguridad nos esforzamos diseñando un tipo de marco que no necesita mecanización y acoge los bulones de una cerradura de alta seguridad multipunto y los conos antipalanca. La estética de sus formas redondeadas y la gama de paneles existentes hacen de esta puerta un lujo para sus propietarios.

Poliuretano inyectado de alta densidad de 16 mm 150 kgs/m<sup>3</sup>.  
Mousse de Polyuréthane d'une haute densité: 16 mm.1150 Kgs/m<sup>3</sup>.  
Injected Polyurethane foam with a high density of 16 mm.1150 Kgs/m<sup>3</sup>.

2 Chapas de aluminio de 2 mm. de espesor.  
2 Tôles d'aluminium de 2 mm. d'épaisseur.  
2 Aluminium sheets with 2 mm. of thickness.



Detalle de sección de perfil.  
Détail de la section du profil.  
Detail of the profil section.

#### LACADOS IMITACIÓN MADERA



#### LACADOS GAMA RAL



#### SÉRIE ALUMINIUM RUPTURE THÉRMIQUE: LE PLUS RÉSISTANT

Ce type de porte a été pensé pour donner la meilleure sûreté pour l'entrée de la maison, avec ses trois joints Epdm et double system coupe-vent inférieur, nous la convertissons en une porte étanche. La rupture thermique évite les condensations propre à l'aluminium et il permet la double termination intérieure-extérieure (bicolore), de même en sécurité nous avons fait des effort en dessinant un type de dormant qui n'a pas besoin de mécanisation et accueille les fixations d'une serrure de grande sécurité multipoint et les cônes anti-degoudage. L'esthétique de ses formes arrondis et la gamme des panneaux existants font de cette port un luxe pour ses propriétaires.

#### SERIE ALUMINIUM ISOLATION CHAMBER: THE MOST RESISTANT

This kind of door was designed for giving more security to the entrance of the house, with his three joints EPDM and double inside wind breaker, we make of this one a very tightness door. The thermal bridge avoid the condensation of the aluminium and allows the double finishing inside – outside (bicolour). And also in security we make an effort designing a kind of marc, which do not need mecanisation and has the coupling of a locking of high quality multipoints and the cone anti-lever. The aesthetics of his round form and the range of existing paneeldoors make this finished door a luxury for their proprietor.

Disponible en cualquier color de la gama RAL y en lacado imitación madera.  
Disponible en toutes couleurs de la gamme RAL autant pour des laques de l'imitation bois.  
Disposal in all the colours of the range RAL and also for the lacquer of wood-imitation.

#### SECCIÓN HORIZONTAL

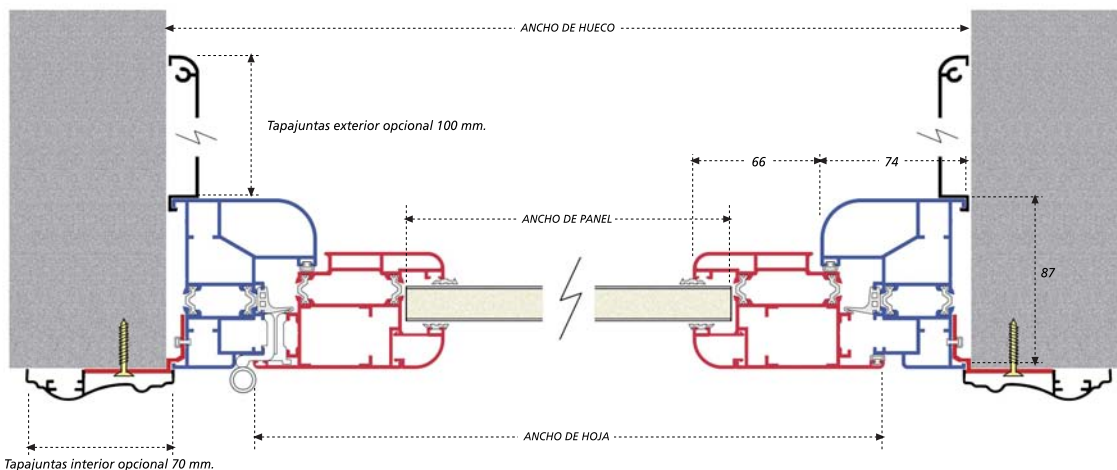

#### SECCIÓN VERTICAL

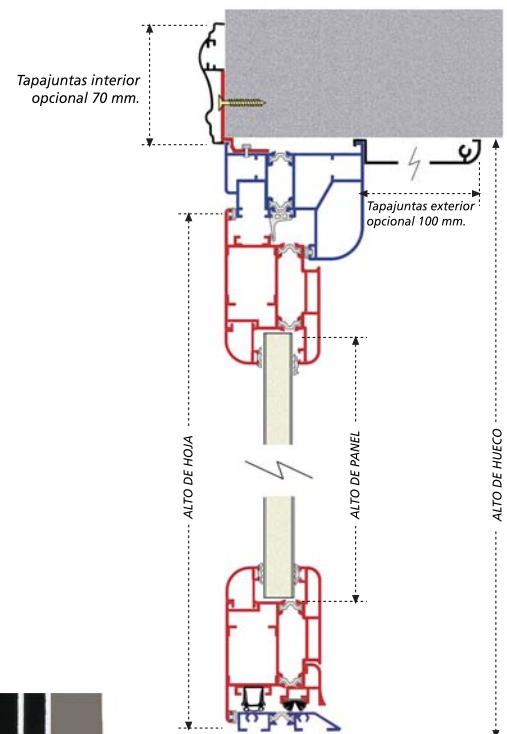

Conos antipalanca  
Cônes anti-degoudage  
Cones antilever

3 bisagras regulables  
3 charnière regulable  
3 regulable hinge

Detalles de bisagra.  
Détails de charnière.  
Details of hinge.

Cerradura de seguridad especial de gancho, 5 puntos.  
Serrure de sûreté spéciale de crochet, 5 points.  
Safety locking special with hook, 5 points.

Doble sistema cortavientos estanco.  
Double system coupe vent d'étanchéité.  
Double system and waterproof wind breacer.

## PUERTA COMPLETA

### HOJA OCULTA - OUVRANT CACHÉ - HIDDEN LEAF

#### SERIE ALUMINIO ROTURA HOJA OCULTA: LA MÁS NOVEDOSA

Sin lugar a dudas, el diseño de una puerta de estas características totalmente en aluminio con rotura térmica ha sido un reto para nuestros diseñadores. La ocultación de la hoja en rotura térmica permite ofrecer una puerta de una belleza inigualable. Partiendo siempre de las características que hemos impuesto para todas nuestras series, las triples juntas de estanqueidad, los cortavientos, las cerraduras de alta seguridad multipunto y por último los conos antipalanca, confieren un conjunto bello, seguro y armonioso, con todas las posibilidades del bicolor.

Poliuretano inyectado de alta densidad de 36 mm 150 kgs/m<sup>3</sup>  
 Mousse de Polyuréthane d'une haute densité: 36 mm.150 Kgs/m<sup>3</sup>  
 Injected Polyurethane foam with a high density of 36 mm.150 Kgs/m<sup>3</sup>.

2 Chapas de aluminio de 2 mm. de espesor.  
 2 Tôles d'aluminium de 2 mm. d'épaisseur.  
 2 Aluminium sheets with 2 mm. of thickness.



Detalle de sección de perfil.  
 Détail de la section du profil.  
 Detail of the profil section.

LACADOS  
 IMITACIÓN  
 MADERA



LACADOS  
 GAMA RAL



**SERIE ALU RUPTURE OUVRANT CACHÉ: LA PLUS NOUVELLE**  
 Il n'y a pas de doute, le dessin d'une porte de cette caractéristique totalement en aluminium avec rupture thermique a été un défi pour nos dessinateurs. L'occultation d'ouvrant en rupture thermique a permis d'offrir une porte d'une beauté inégalable. En partant toujours des renseignements techniques que nous avons imposés pour toutes nos séries, les triples joints d'étanchéité, les coupe-vent, les serrures de haut sûreté multipoint et finalement les cônes anti-degoudage, attribuent un ensemble bel, sûr et harmonieux, avec toutes possibilités de la bicoloration.

**SERIE ALUMINIUM HIDDEN LEAF: THE MOST NEW**  
 Without doubt, the design of a door of this characteristics completely in aluminium with thermal break was a challenge for our designers. The conceal of the leaf in isolation chamber permit to offer a door with a beauty unsurpassable. Counting ever from the characteristics that we have impose for all our series, the three waterproof joints, the wind breaker, the locking of high security multipoints and at last the cones anti-lever make an beauty assembly, sure and harmonious, with all the possibilities of bicoloration.

Disponible en cualquier color de la gama RAL y en lacado imitación madera.  
 Disponible en toutes couleurs de la gamme RAL autant pour des lacques de l'imitation bois.  
 Disposal in all the colours of the range RAL and also for the lacquer of wood-imitation.

#### SECCIÓN HORIZONTAL

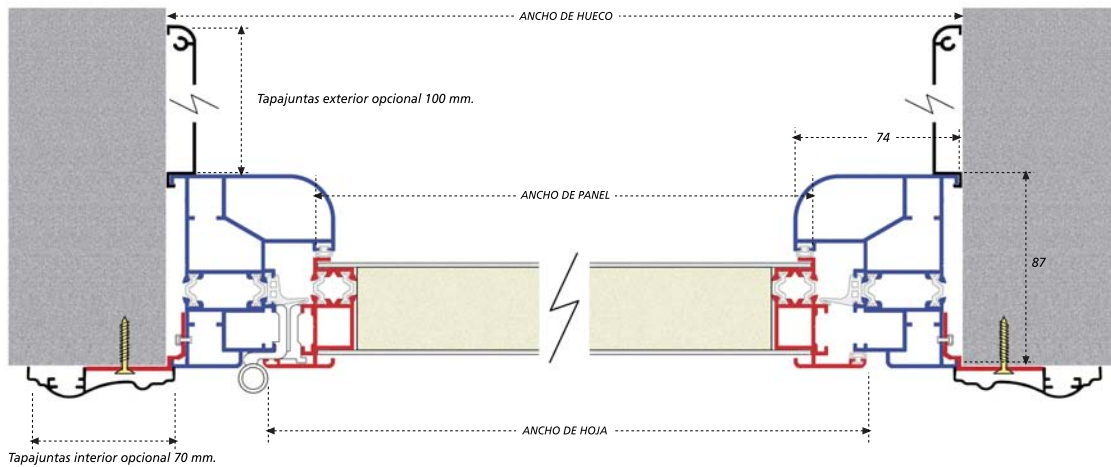

#### SECCIÓN VERTICAL

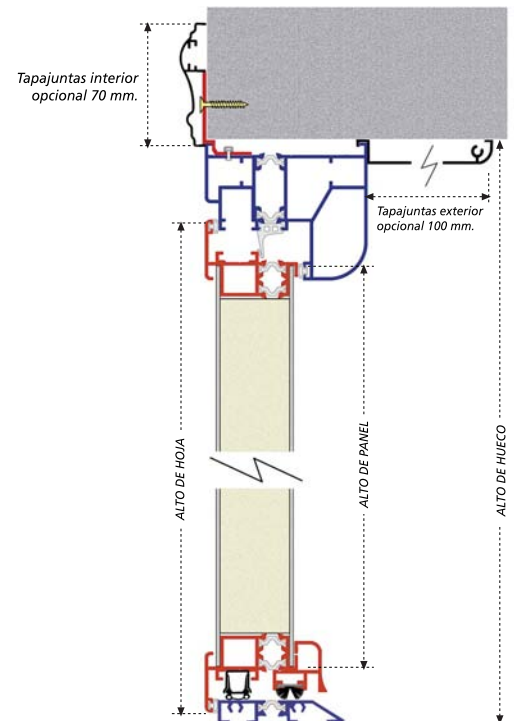

Conos antipalanca  
 Cônes anti-degoudage  
 Cones antilever



3 bisagras regulables  
 3 charnière regulable  
 3 regulable hinge



Detalles de bisagra.  
 Détails de charnière.  
 Details of hinge.



Cerradura de seguridad especial de gancho, 5 puntos.  
 Serrure de sûreté spéciale de crochet, 5 points.  
 Safety locking special with hook, 5 points.

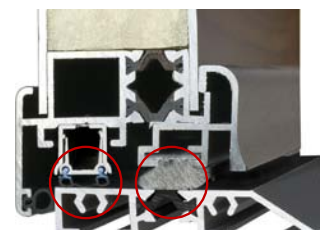

Doble sistema cortavientos estanco.  
 Double system coupe vent d'étanchéité.  
 Double system and waterproof wind breacer.



#### SERIE ALUMINIO + MADERA: LA MÁS ELEGANTE

Que duda cabe que el material más noble de una vivienda es la madera. En esta puerta hemos puesto todo nuestro corazón por convertirla en la más elegante de todas las puertas. Un cierre mixto aluminio por fuera libre de manutención y con la posibilidad de elegir el acabado que más guste (colores, imitación madera), y madera natural en el interior, conjugando armónicamente con el resto de la carpintería del hogar. A todo lo expuesto tenemos que añadir que hemos diseñado unas bisagras antipalanca y hemos optado por una cerradura de alta seguridad con cinco puntos de cierre (dos de ellos de gancho), tres juntas de estanqueidad y doble sistema cortavientos inferior que denotan las características de este cierre convirtiéndolo en una de las más seguras y elegantes.



Disponible en cualquier color de la gama RAL y en lacado imitación madera.  
 Disponible en toutes couleurs de la gamme RAL autant pour des lacques de l'imitation bois.  
 Disposal in all the colours of the range RAL and also for the lacquer of wood-imitation.

#### SÉRIE ALUMINIUM + BOIS: LA PLUS ÉLEGANTE

Pas de doute, il N'Y a que la noblesse du bois pour votre logement. Dans cette conception nous avons tout mis en oeuvre pour donner l'élégance maximum de ces portes. Deux modèles de serrure haute sécurité (5 points) sont proposées. Les différentes finitions, laquage ral, laquage imitation bois, etc. facilite grandement l'entretien – la finition bois intérieure se conjugue harmonieusement avec les autres menuiseries. A toutes ces innovations nous avons ajouté les charnières anti-degoudage, trois joints d'étanchéité et double système coupe-vent inférieure donstent les grandes caractéristiques de ce type de porte garantissant cette série comme l'une des plus sûres et élégantes.

#### SERIE ALUMINIUM + WOOD: THE MOST ELEGANT

There is no doubt that the most noble material in a housing is the wood. In this door we have make our best to make of this door the most elegant of all the existent doors: A mixed locking aluminium outside free of maintenance and with the possibility to choose the colour that we prefer (colour, imitation bois, etc.), And with natural wood inside, combining harmoniously with the rest of the carpentry of the home. We must add to all the above mentioned, that we have also designed a safety hinge with anti-lever and we choose for a locking of high security with five points of shutting (two of them with hook), three waterproof joints and double inside wind breaker denote the characteristics of this locking, converting this serie in one of the most sures and most elegants.

#### SECCIÓN HORIZONTAL

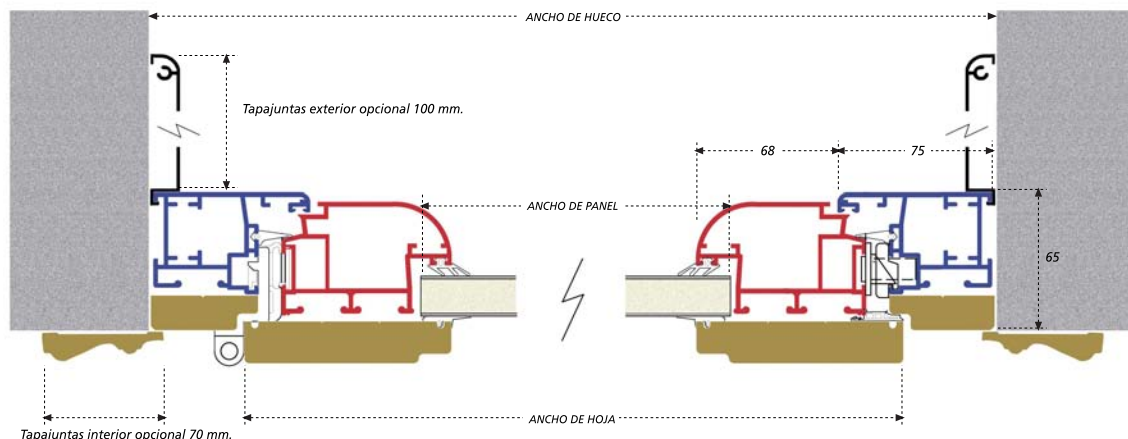

Bisagra antipalanca  
 Charnière anti-degoudage  
 Hinge antilever



Detalle de bisagra.  
 Détail de charnière.  
 Detail of hinge.



Cerradura de seguridad especial de gancho, 5 puntos.  
 Serrure de sûreté spéciale de crochet, 5 points.  
 Safety locking special with hook, 5 points.

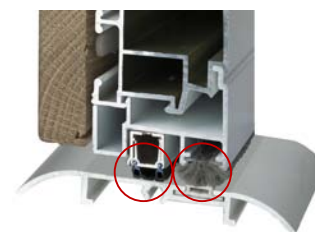

Doble sistema cortavientos estanco.  
 Double system coupe vent d'étanchéité.  
 Double system and waterproof wind breacer.

Poliuretano inyectado de alta densidad de 16 mm 150 kgs/m<sup>3</sup>.  
 Mousse de Polyuréthane d'une haute densité: 16 mm./150 Kgs/m<sup>3</sup>.  
 Injected Polyurethane foam with a high density of 16 mm./150 Kgs/m<sup>3</sup>.

2 Chapas de aluminio de 2 mm. de espesor.  
 2 Tôles d'aluminium de 2 mm. d'épaisseur.  
 2 Aluminium sheets with 2 mm. of thickness.

Contrachapado de madera de 4 mm.  
 Doublé en bois de 4 mm.  
 Plywood of 4 mm.



Detalle de sección de perfil.  
 Détail de la section du profil.  
 Detail of the profil section.

#### SECCIÓN VERTICAL

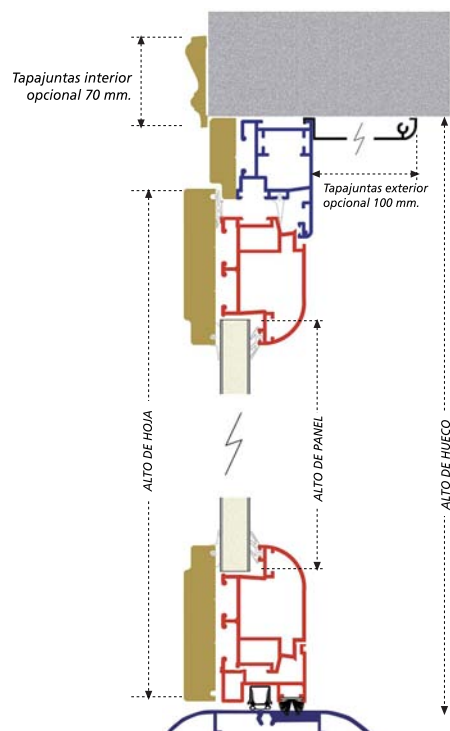



## ACCESORIOS

### HERRAJES

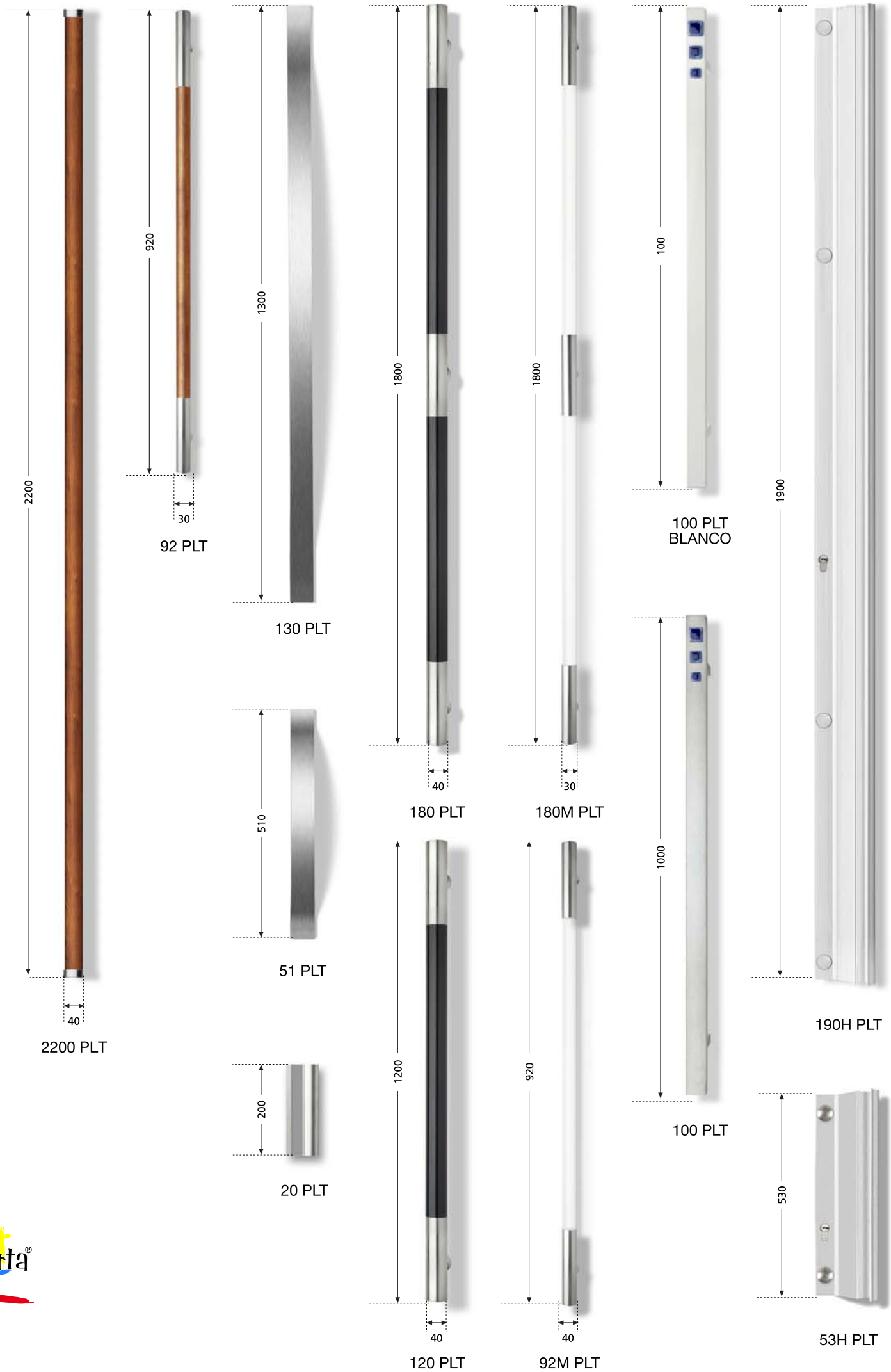

## ACCESORIOS

### HERRAJES Y CRISTALES

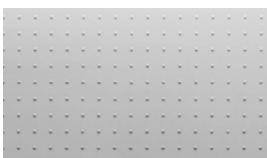
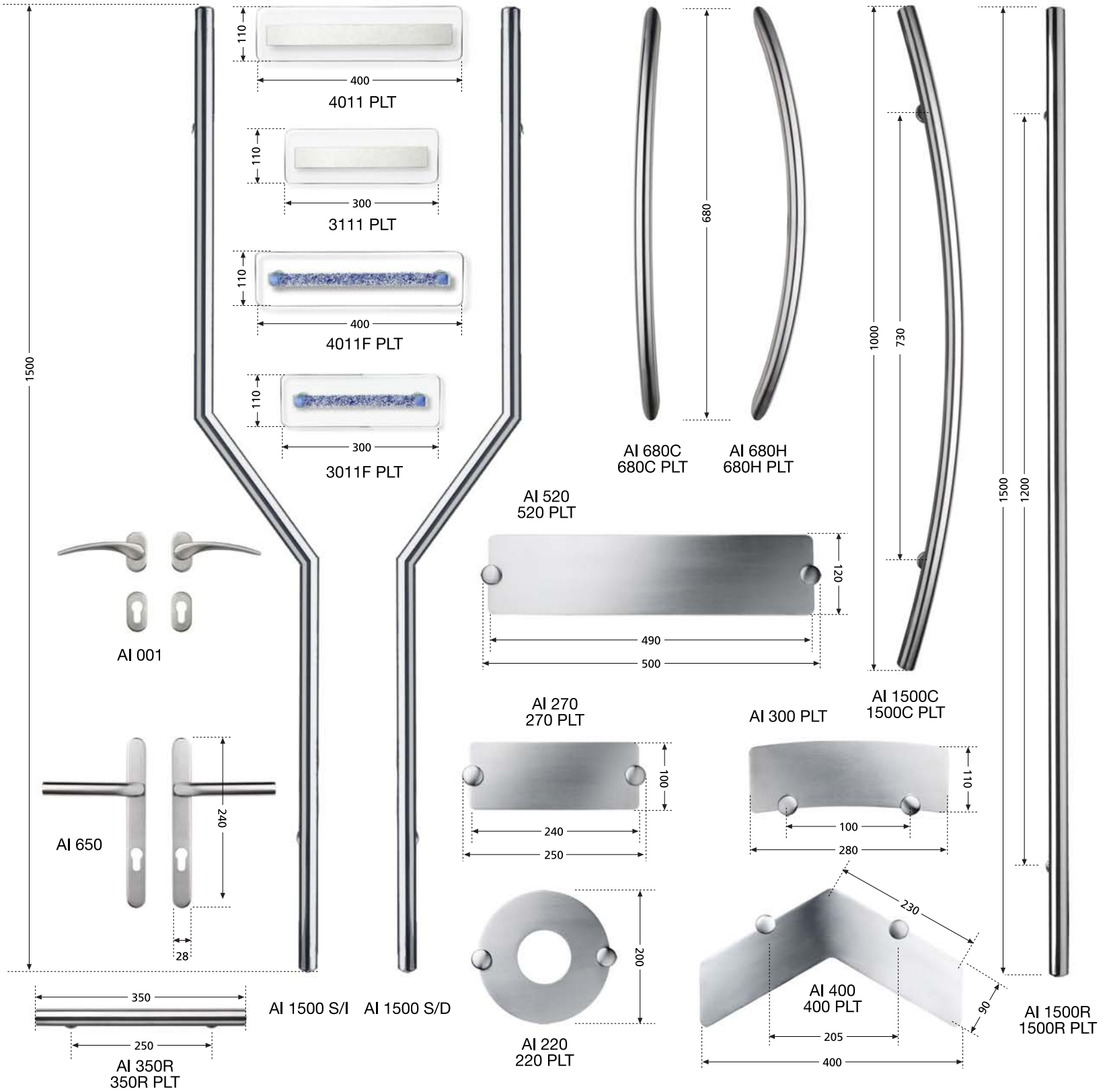

PICKS

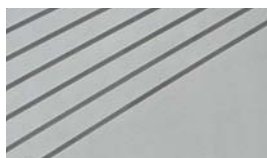

ARENADO



FUSSING



TON



ORION



RAYON OCRE



ASTRAL



HOJAS



ELEGANT

## DISEÑO DE LOS PANELES

DIMENSIONES, COTAS, ESPESTORES / MEASURES, COTES, EPAISSEUR / DIMENSIONS, MEASURE, THICKNESS

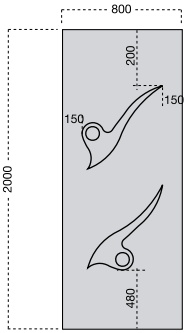

**ACTINIO**

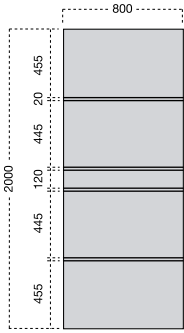

**ARGON**

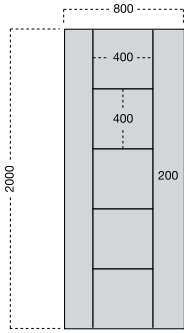

**ASTATO**

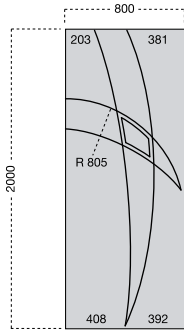

**AZUFRE**

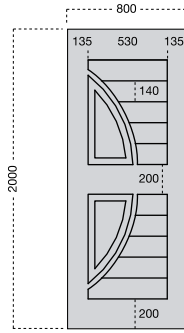

**BARIO**

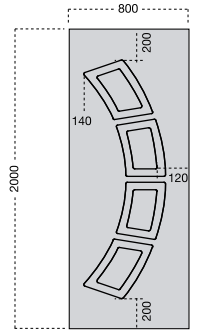

**BERILIO**

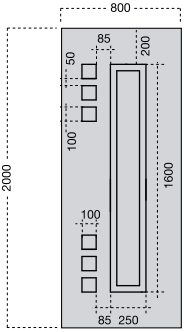

**BISMUTO**

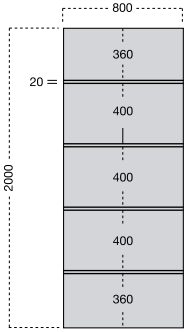

**BORO**

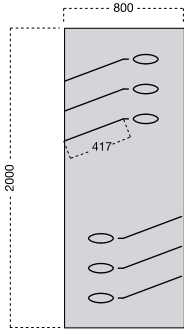

**CADMIO**

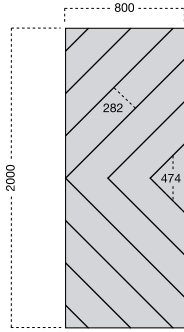

**CARBONO**

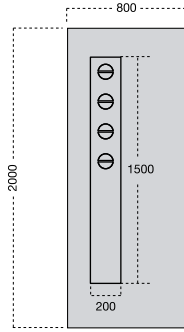

**CESIO**

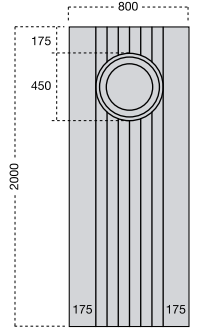

**CINC**

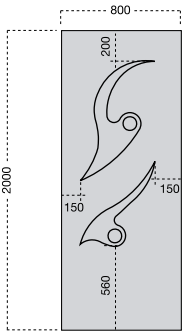

**CIRCONO**

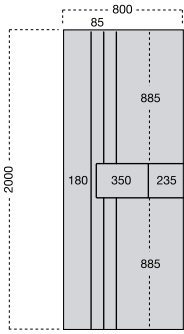

**CLORO**

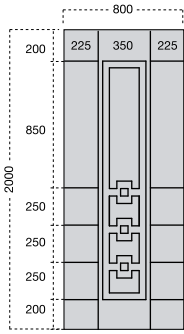

**COBALTO**

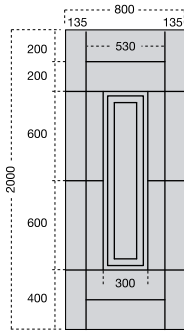

**COBRE**

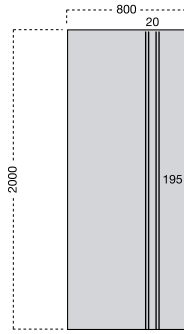

**CRIPTON**

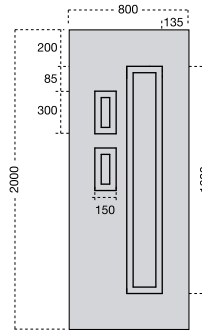

**CROMO**

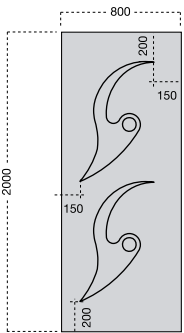

**DUBRIO**

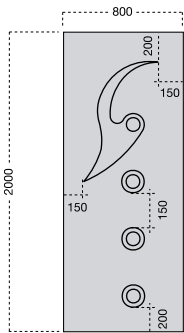

**ESCANDIO**

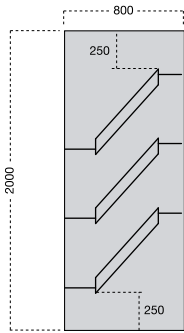

**ESTAÑO**

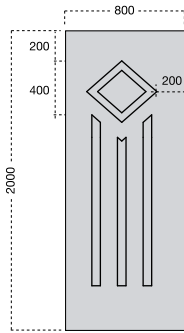

**ESTRONCIO**

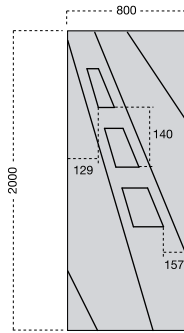

**FLUOR**

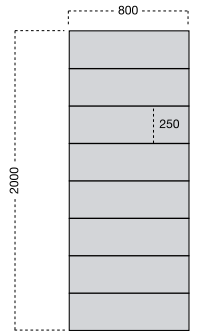

**FOSFORO**

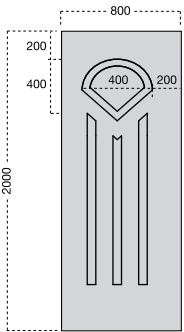

**FRANCIO**

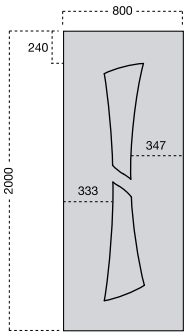

**GALIO**

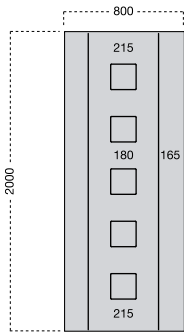

**HELIO**

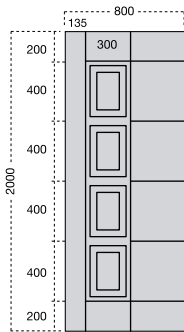

**HIERRO**

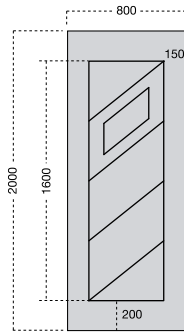

**INDIO**

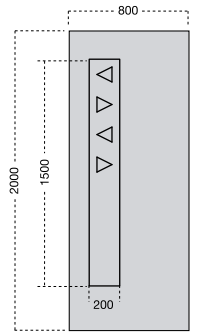

**LITIO**



## DISEÑO DE LOS PANELES

DIMENSIONES, COTAS, ESPESORES / MEASURES, COTES, EPAISSEUR / DIMENSIONS, MEASURE, THICKNESS

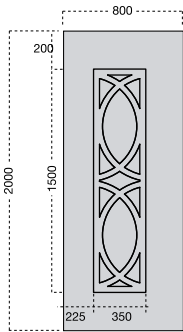

**MAGNESIO**

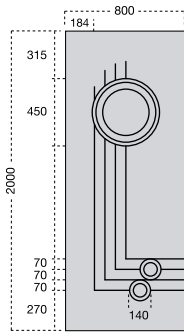

**MANGANESO**

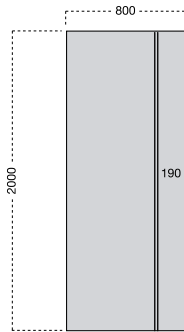

**NEON**

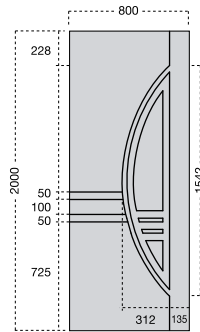

**NIQUEL**

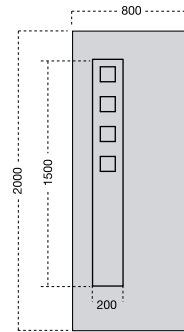

**OSMIO**

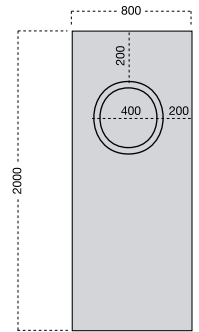

**PALADIO**

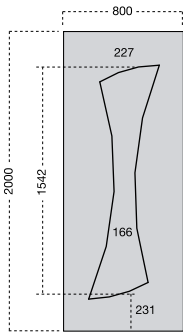

**PLATINO**

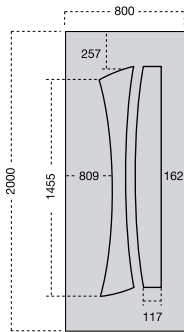

**PLOMO**

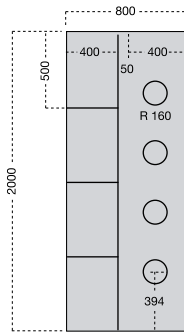

**POLONIO**

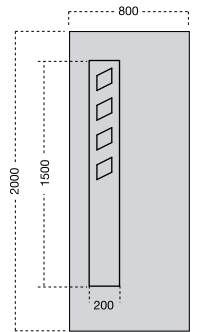

**POTASIO**

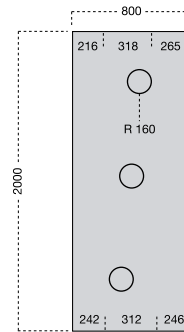

**RADON**

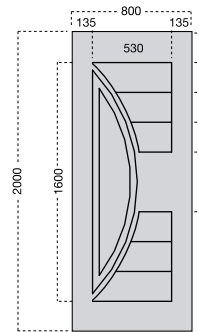

**RODIO**

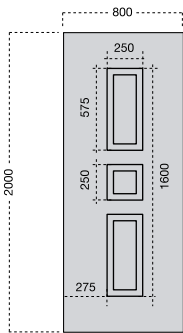

**RUBIDIO**

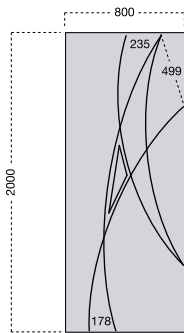

**SELENIO**

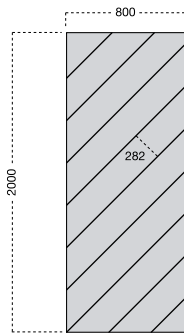

**SILICIO**

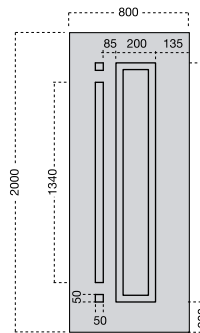

**SODIO**

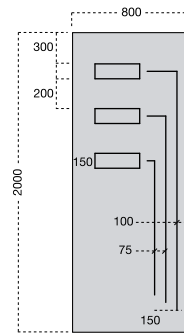

**TELURO**

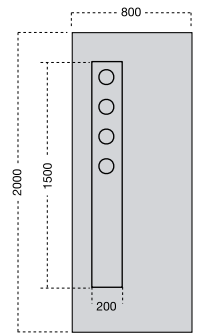

**TITANIO**

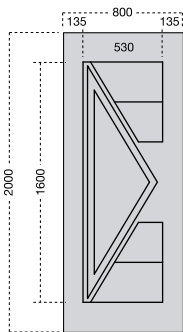

**VANADIO**

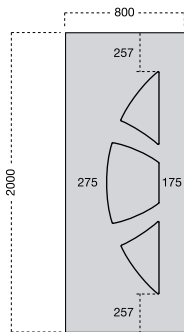

**XENON**

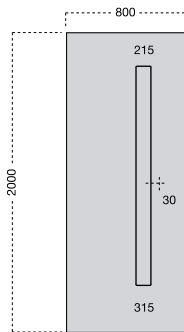

**YODO**

**Medidas paneles puerta:  
Panel doors dimensions:  
Measures panneaux porte:**

Todos los paneles standard tienen unas dimensiones de:

*Standard measures for panels*

Tous les panneaux standards ont des dimensions de:

2000 x 800 2100 x 900

2000 x 500 2100 x 500

Espesores/  
Thickness/

Epaisseur:

20 mm.

24 mm.

28 mm.

33 mm.

40 mm.

## MARQUESINAS - MARQUISES - CANOPIES

### ALUPORTA TE PONE A CUBIERTO CON SUS MARQUESINAS

Fabricado en metacrilato/policarbonato rígido con soporte de aluminio lacado, disponible en varias medidas y colores, con opción de luz de bajo consumo.

### ALUPORTA TE METS À L'ABRI AVEC SES MARQUISES

Fabriquées en méthacrylate/polycarbonate rigide avec un support d'aluminium laqué, disponible en différentes dimensions et couleurs, avec l'option d'une lumière de consommation basse.

### ALUPORTA PUT YOU UNDER COVER WITH THEIR CANOPIES

Manufactured in rigid methacrylate/polycarbonate with a painted aluminium support, available in different dimensions and colours, with the lightoption of low consumption.

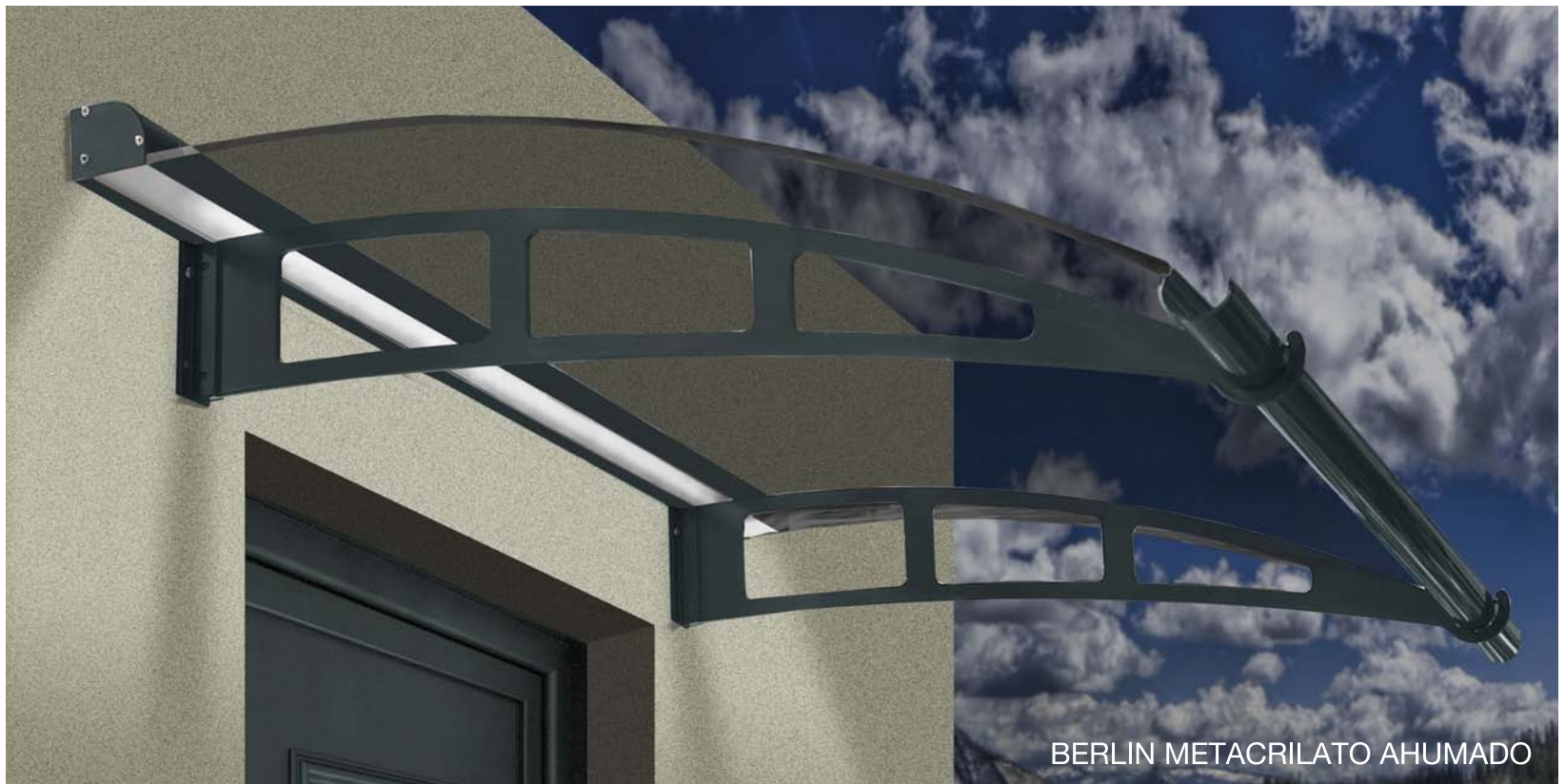



## MARQUESINAS - MARQUISES - CANOPIES

Disponibile en cualquier color de la gama RAL y en lacado imitación madera.

Disponibile en toutes couleurs de la gamme RAL autant pour des lacques de l'imitation bois.

Disposal in all the colours of the range RAL and also for the lacquer of wood-imitation.



COLORES  
METACRILATOS /  
POLICARBONATOS

Consultar otros acabados.  
Consulter autres finitions.  
Ask for other finished.

DIMENSIONES  
MEASURES  
DIMENSIONS

150 x 90

200 x 90

250 x 90

ACABADOS / FINISH / FINITION

RAL



IMITACIÓN MADERA



ANODIZADOS



VARSOVIA POLICARBONATO

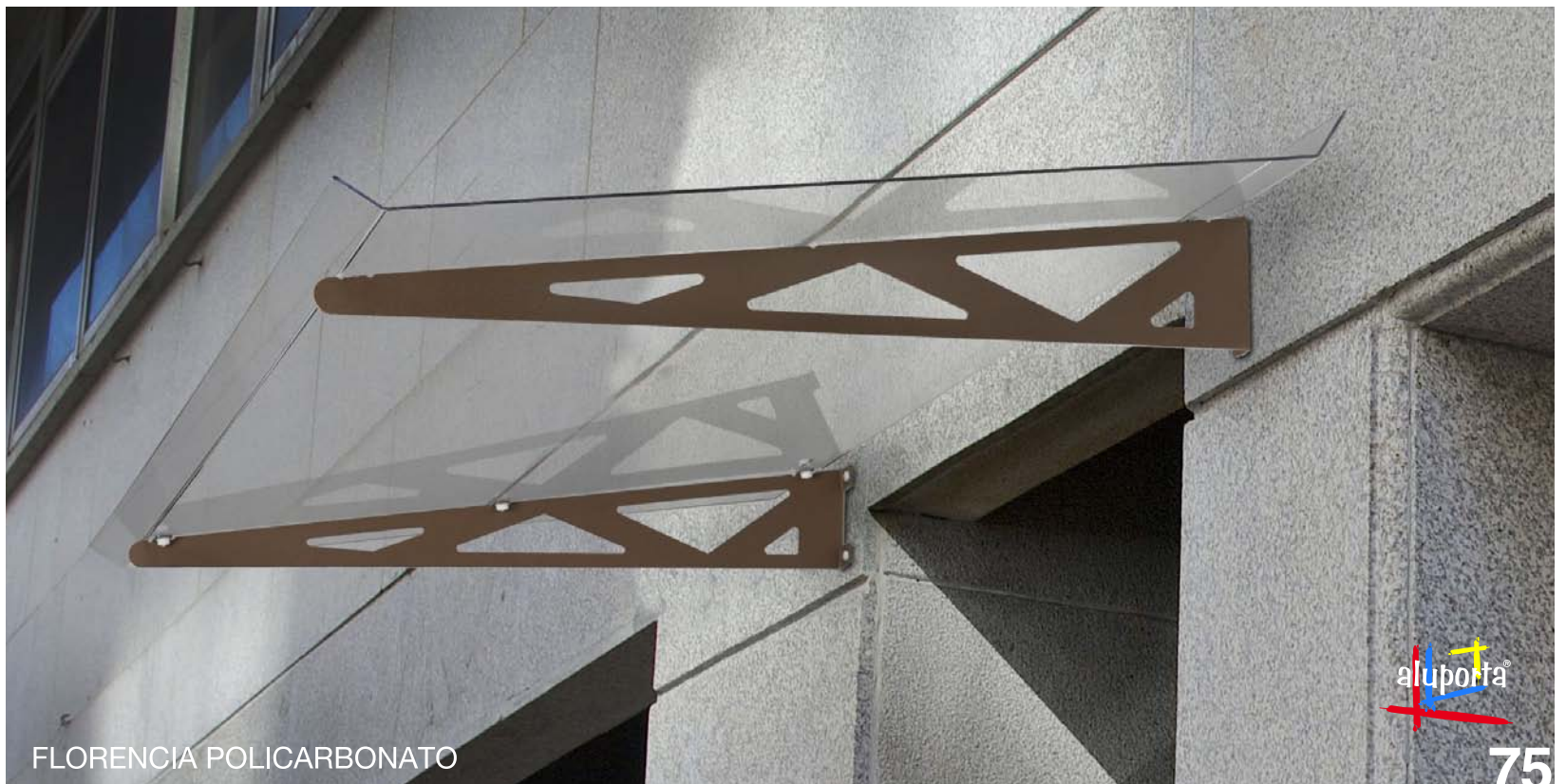

FLORENCIA POLICARBONATO





**ALUORTA S.L.**

Polígono Industrial "A GRANXA"  
Paralela 2 - Parcela 16  
36400 PORRIÑO (Pontevedra) España  
Tlf.: +34 986 337 787 - Fax: +34 986 337 778  
e-mail: [informacion@aluporta.com](mailto:informacion@aluporta.com)  
[www.aluporta.com](http://www.aluporta.com)

PROXECTO FINANCIADO



**XUNTA DE GALICIA**  
CONSELLERÍA DE  
ECONOMÍA E INDUSTRIA